

# KAUOHENG



## KH-313N OPERATION MANUAL

電腦橫編織機

KH

COMPUTERIZED FLAT KNITTING MACHINE

**DEAR CUSTOMER :**

Welcome to be an owner of KH-313N computerized flat knitting machine as Kao Heng endeavors to maintain a high standard of this machine, we also pleased for your cooperation to make the machine serve longer by reading this operation manual carefully before commencing your production.

Yours sincerely,

Kao Heng Precision Machinery Industrial Co., LTD.

Address : No. 20, Lane 14, Ho Ping Rd., Panchiao, Taipei, Taiwan

Tel : 886-2-29559258

Fax : 886-2-29629153

E-mail : [kauoheng@ms58.hinet.net](mailto:kauoheng@ms58.hinet.net)

Website : [www.kauoheng.com.tw](http://www.kauoheng.com.tw)

# OVERVIEW OF KH-313N

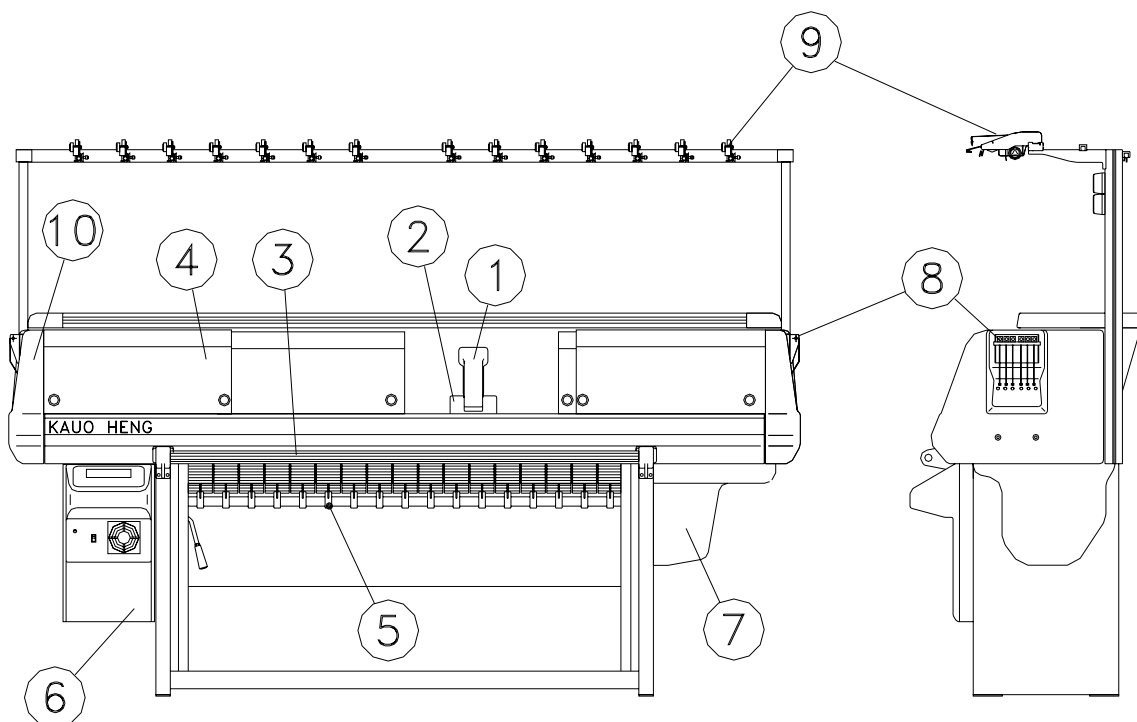

1. Yarn carrier selection
2. Carriage
3. Operation bar
4. Main cover
5. Fabric take-down roller
6. Controller
7. Main motor
8. Side tension
9. Top tension
10. Side cover

## 1. Points to observe

### ① Installation Environmental Conditions

Please install the machine as below instructions in order to use this machine in the best condition for a long period of time.

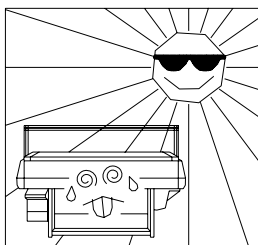

Do not install the machine at a place subject to direct sunshine and/or adjacent to a heat generation source such as a furnace/oven.

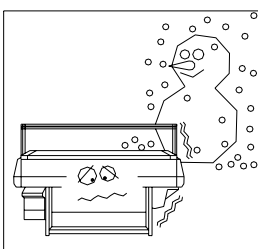

Do not install the machine at a place subject to rapid temperature changes.

The temperature should be 0°C ~ 35°C inside the controller.

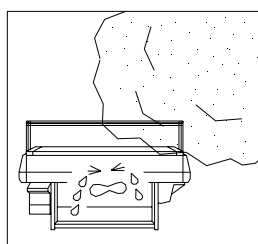

Do not install the machine at a place where there is a lot of dust and dirt, or a location affected by chemical gases, sea breeze etc.

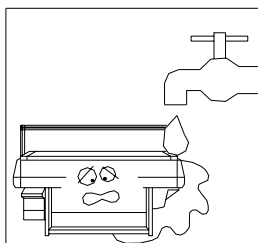

Do not install the machine at a place subject to excessive moisture.

The humidity should be 30 % ~ 80 %

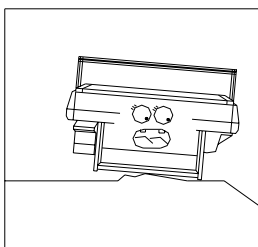

Do not install the machine on a slope or unstable place.

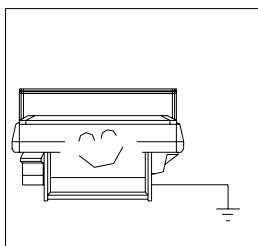

Please connect the electric power and make sure the ground wire is connected correctly.

- ② Fig.1-1 illustrates the correct position of jacking while moving the machine. It is very important when moving the machine. The yarn carrier rail shall never be used to push the machine since it will distort the rail.

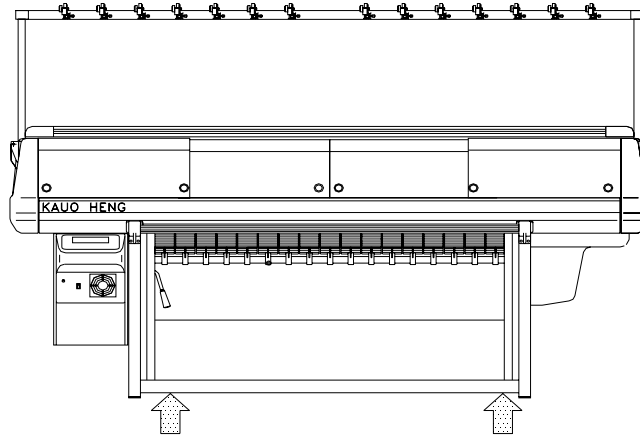

Fig.1-1 Correct position of jacking the machine

- ③ When connecting the electric power, attention must be paid to the correct voltage. And make sure the ground-wire connected.

## 2. Installation

- ① After unpacking and locating the machine in the factory, it must be leveled carefully with a spirit-level to avoid machine distortion in running. We recommend the machine to be leveled with rubber peddings for best result. Remove grease from the polished parts before starting to operate the machine. About the moving parts must be lubricated according to the following instruction.

Lubrication points	Lubricant	Frequency
Carriage	# 10 oil	Daily
Carrier rail	# 10 oil	Daily
Needle bed	# 10 oil	Daily
Driving parts	Hi-temp grease	Weekly

Table 2-1 Lubrication

- ② Raise the yarn stand till the end of the tubes is leveled with the base plate, tighten the screws and connect the plug of stop motion situated at the left rear end.

### 3. Operation

#### 3-1 Power switch

As Fig.3-1 front side of controller, easily find two switches. Flip upward is "ON" and downward is "OFF".

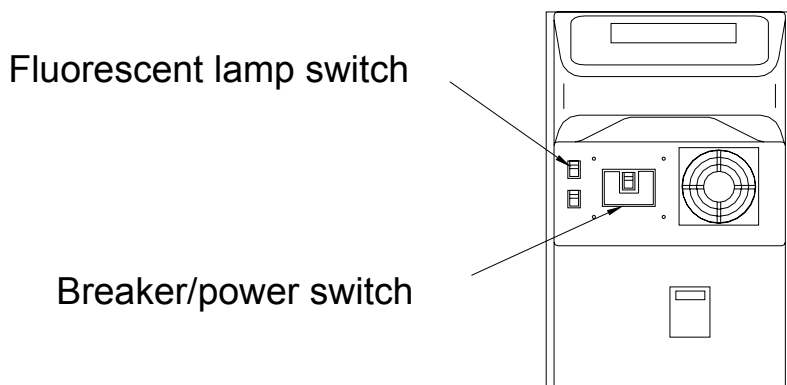

Fig.3-1 Front side of controller

#### 3-2 Operation bar

3-2-1 Inching : When turning forward of the operation bar, machine operates slowly and stops when you loosen.

3-2-2 Starting : When turning backward of the operation bar, machine starts. Machine starts from slow speed and runs in preset speed when reaching the first terminal sign.

3-2-3 Stop : When the machine is running, you can turn operation bar in any direction to stop machine.

3-2-4 Machine executes protection mode automatically when machine stops over 3 seconds. You must turn twice backward of the operation bar to start.

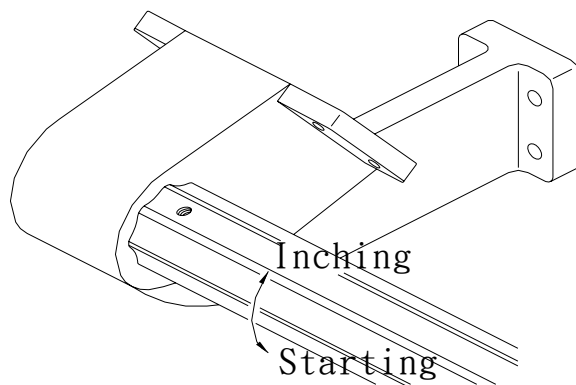

Fig.3-2 Starting operation bar

### 3-3 Yarn feeder

The position of carrier is adjusted according to the desired knitting width, correctly make yarn feeder beside the end working needle by 10 mm. The yarn feeder must be in the central position between front and rear needles, also check its height refer to Fig.3-3-1. When work several yarn feeder in knitting, the position of carrier should be adjusted to make each yarn feeder not be overlapped, it avoids damage of the parts. The yarn carrier on rail must be adjusted in easy moving, adjustment refers to Fig.3-3-2.

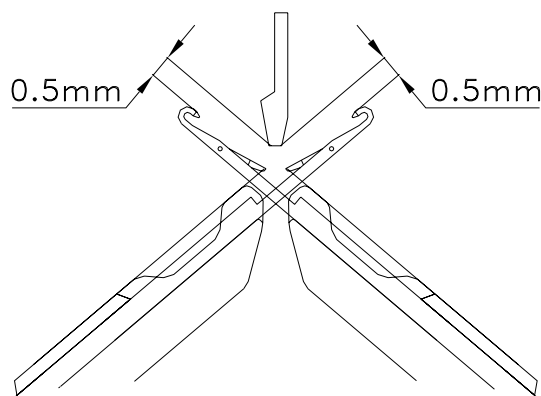
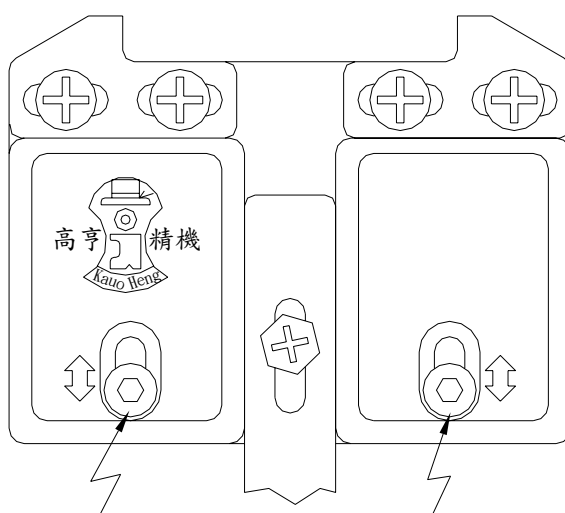

Fig.3-3-1 Position of yarn carrier



Loosen two screws to adjust up & down

Fig.3-3-2 Adjustment of carrier

### 3-3-3 Yarn carrier for Lycra Tuck



Fig.3-3-3 Yarn carrier for Lycra Tuck

### 3-4 Top tension

Top tension springs should have the correct tension, the opening of the knot-catcher must be set according to the yarn count that is being knit-ted.

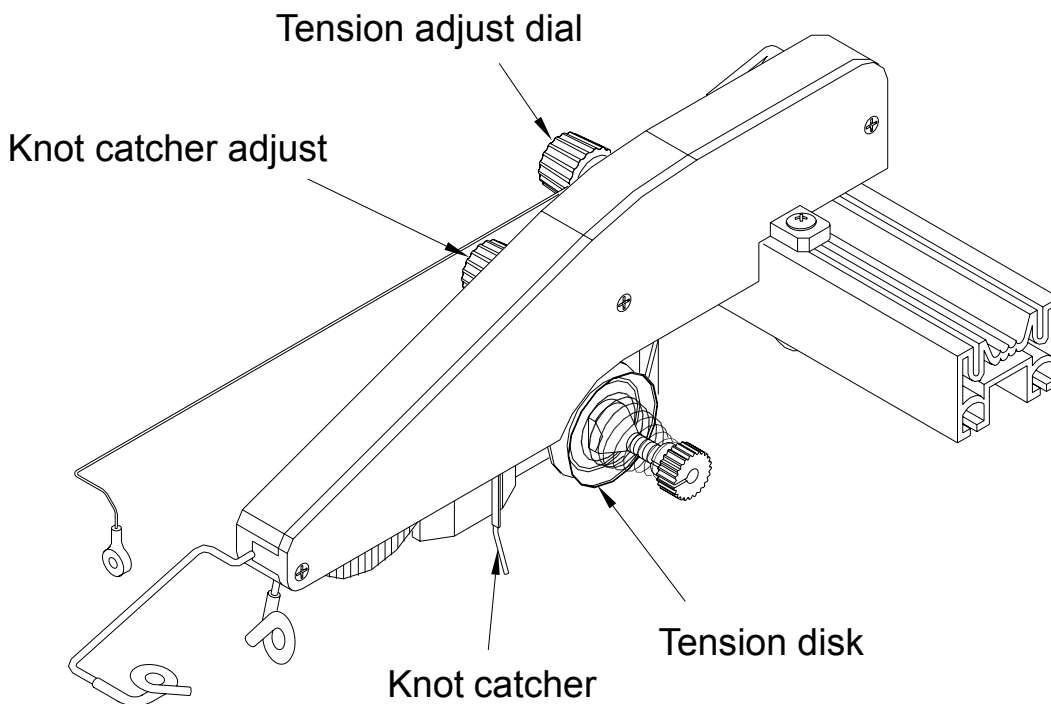

Fig.3-4-1 Top tension



### 3.5 The latch brush

Latch brush is important to prohibit the needle latch to close in knitting, the correct brusk setting is illustrated in Fig.3-5-1.

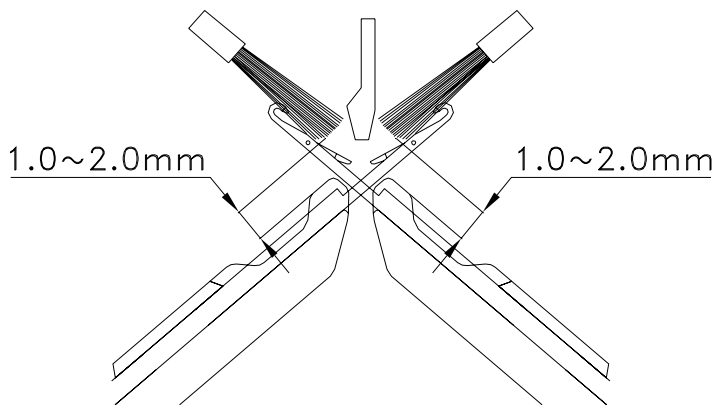

Fig.3-5-1 Correct position of brush

### 4. Clear filter

Filters are equipped in the controller and in the parts of main motor, it prohibits dust to come inside. Please take out the filter and dust it offen refer to Fig.4-1.

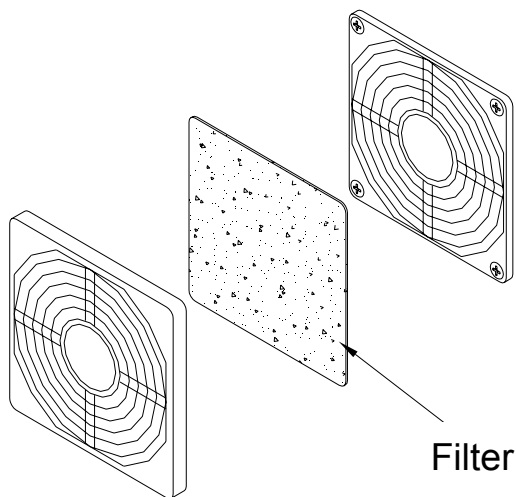

Fig.4-1 Cleaning filter

### 5. Needle bed

KH-323N the structure of front and rear needle bed is the same with regular needles high butt and low butt.

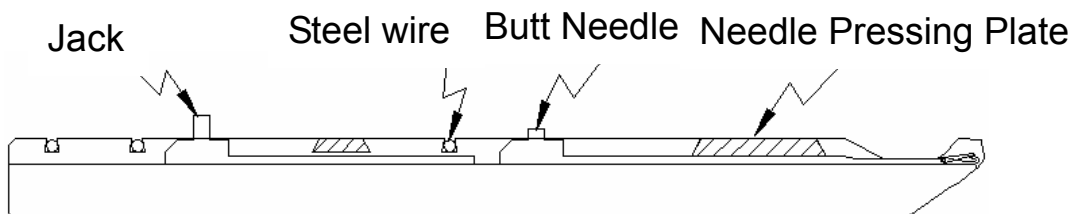
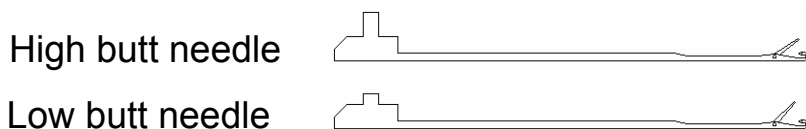

Fig.5.1 The structure of front & rear needle bed

These unused butt needles and jacks you just push them down to the unworked position. Of course you must pull out and back the steel wire A and B for procedure.

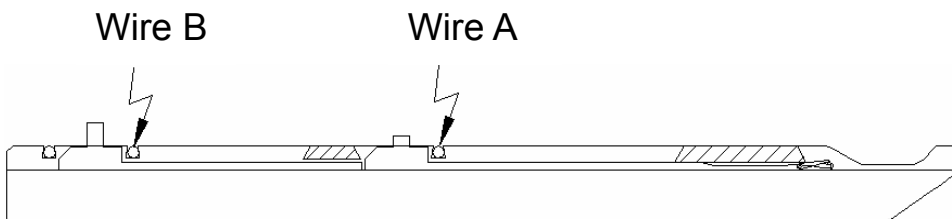

Fig.5-2 Unworked position

## 6. Cam plate distance

The distance between cam plate and needle bed is maximum 0.1 mm, Fig.6-1 shows how to check and adjust. Please check it by every 3 months, loosen the stepped screw and turn the bearing pin to adjust the distance, make sure to tighten the stepped screw after adjustment.

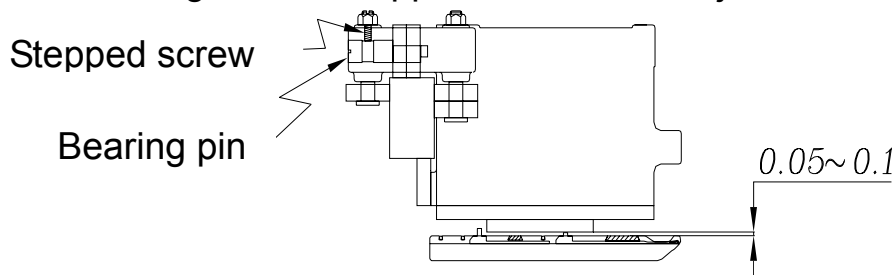

Fig.6-1 Adjust cam plate distance

## 7. Remove carriage

When it becomes necessary to remove the carriage, it can be removed from the left hand side or the right hand side. The procedures are as following :

- ① Turn off the power firstly.
- ② Remove the side cover.
- ③ Disconnect the two plugs on back of carriage.
- ④ Remove the fitting screw and cap bolt on connecting plates as shown in Fig.7-1. Then pay attention to remove the carriage.
- ⑤ After replacing the carriage, it must be confirmed that the plugs, fitting screws and cap bolts are all completely connected, then start machine.

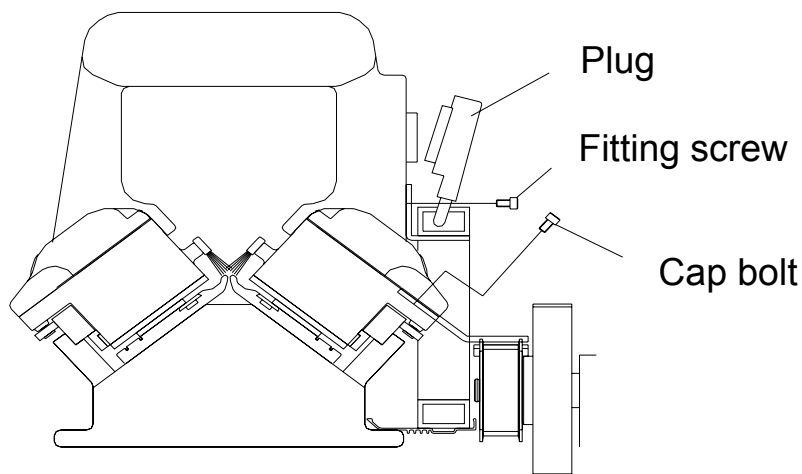

Fig.7-1 Remove the carriage

## 8. Fabric take-down system

In principle of the take-down tension strength must be small and average. The take-down system is controlled by torque motor. There are two important things to adjust the take-down tension strength.

First method is the two speeds No.1 and No.2 as Fig.8-1 adjust each with turning knob and set the speed, the tension strength is larger and the speed is faster. You input the numeric in program to select the speed you want.

Second method is the roller. Each roller can be adjusted individually. The pressure of roller gets larger and the speed of fabric take-down gets faster.

- ⊙ To detect fabric falling or wraparound, there is equipped with a press-off detector in the front of roller and a fabric roll-up detector in the back of roller. The machine will stop automatically when the fabric happens fall or wraparound.

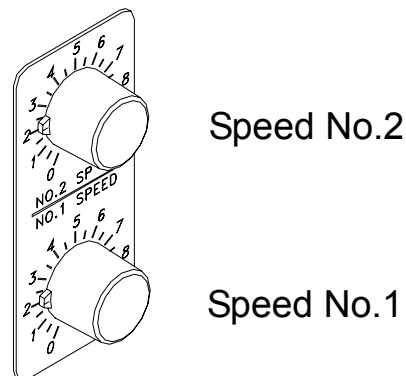

Fig.8-1 Micro adjustment of torque motor

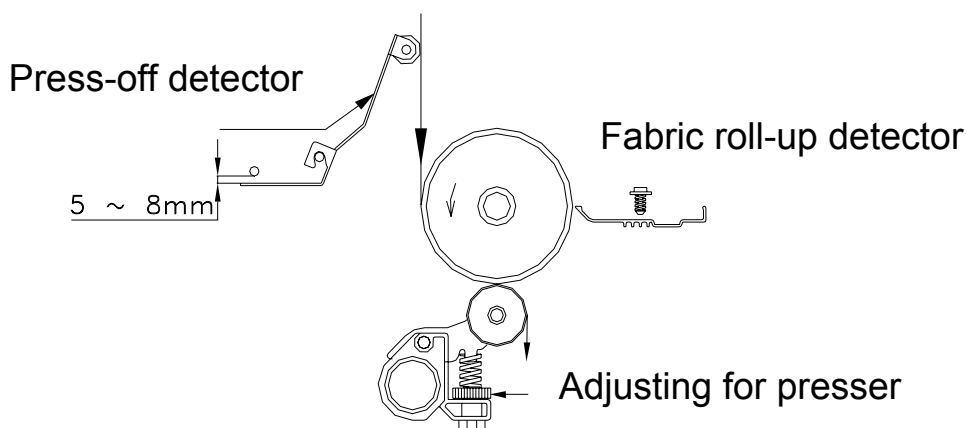

Fig.8-2 Fabric take-down system

## 9. Racking mechanism

- ① The rear bed can be racked five ( 5 ) pitches, the initial position "0". See the left selvedge of needle bed, the corresponding position that the first needle of rear is on the left hand side of the first needle of front. As shown in Fig.9-1.
- ② In editing instruction you can choose the left racking or the right racking by one pitch.
- ③ In each racking position the rear bed and the front bed must be kept in correct corresponding relation. You check it with pushing one front needle to tuck position, the hook of front needle and the knock-bit of rear bed should be at the same position.

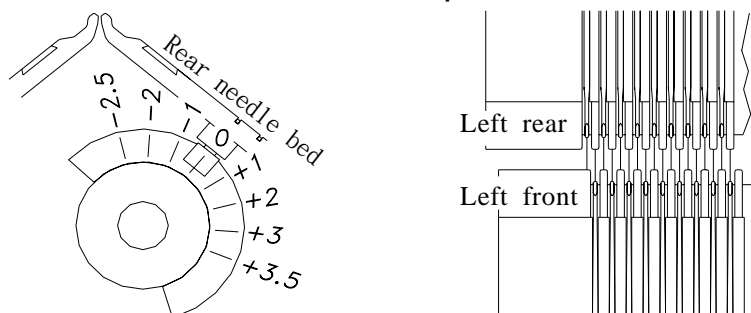

Fig.9-1 Intial position of needle bed

- ④ If there has racking instruction in programming, you must enter the test mode to rack the needle bed in the set position before you execute tun, and make sure the racking mechanism is matched your programming.
- ⑤ Needle position of transfer must be at the left -2.5 and at the right +3.5 of needle bed.
- ⑥ If the corresponding position of needle bed is not proper, loosen the stepped screws and adjust the rear bed to correct position, then tighten the stepped screws after adjustment. Refer to Fig.9-2.

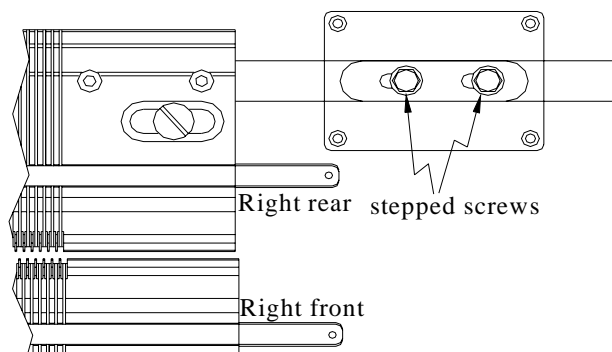

Fig.9-2 Adjusting the position of needle bed

## 10. Special system

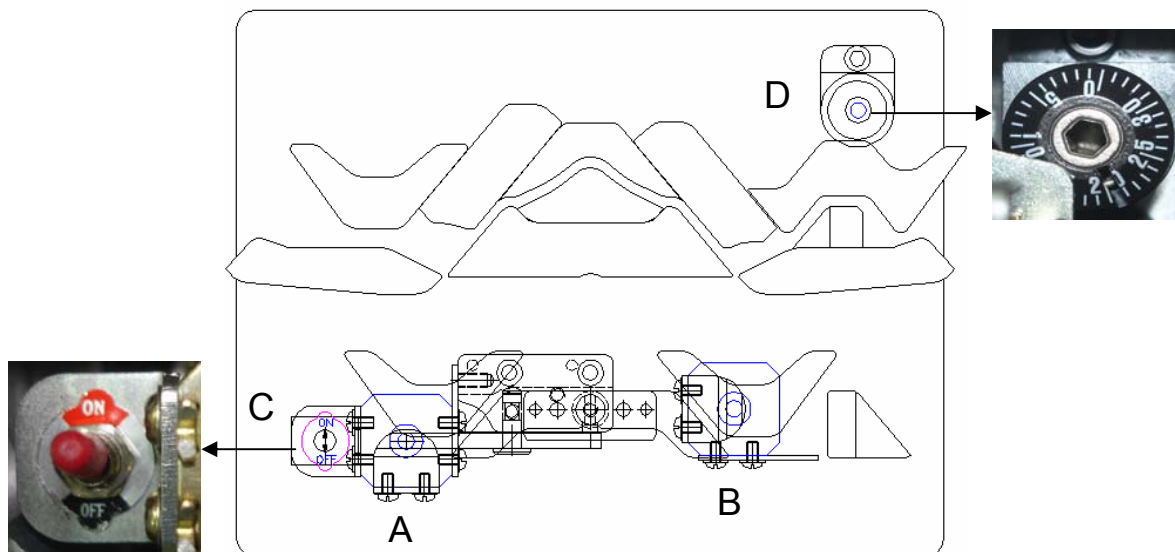

Fig.10-1 Overview of special system

A : 313J solenoid

B : Lycra Tuck solenoid

C : Switch for A (313J solenoid) & B (Lycra Tuck)

※ Make sure if unused solenoid will make cam raise with no action when turning ON & OFF switch.

Switch is “OFF” – Function of KH-313J

Switch is “ON” – Function of KH-313 ( Cam : 0~5) + Lycra Tuck : 1 needle Tuck, I needle Miss and set Take-down : 5 in program data

If Lycra All Tuck should be used, please push all jacks to worked position and change to high butt needle to knit.

D : Adjustment for sitich of Lycra Tuck

Degree of tightness for Lycra : ↷ = Loose, ↶ = Tight

## 11. Cam system

KH-313N the cam system of front & rear needle bed is the same.

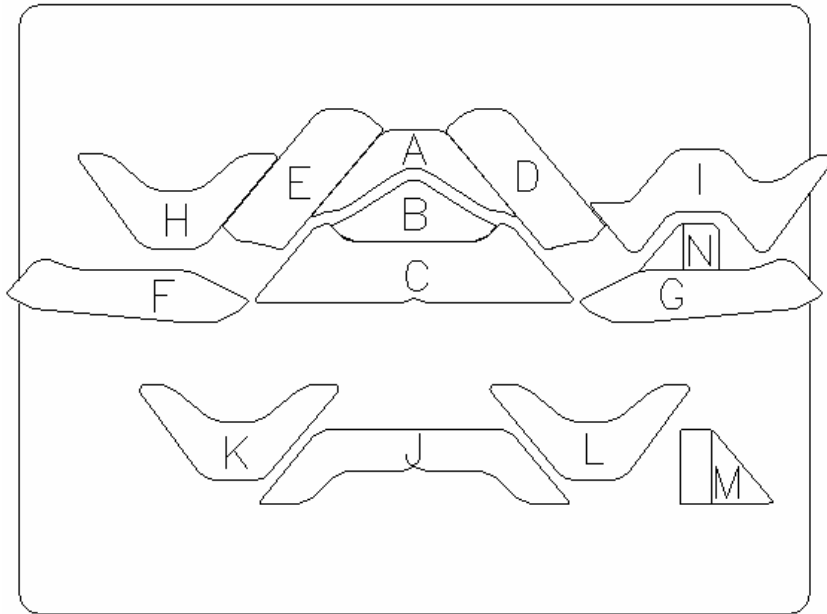

Fig.11-1 Front & rear cam system

- A Bridge cam
- B Needle clearing cam
- C Needle raising cam
- D Stitch cam
- E Stitch cam
- F Needle guide cam
- G Needle guide cam
- H Stitch guide cam
- I Stitch cam
- J Jack raising cam
- K Jack guide cam
- L Jack guide cam
- M Jack raising cam
- N Needle raising cam

### 12. Cam action

In graphs show the usual kinds of cam active situation. "ARROW" means the carriage knitting direction.

Cam of SLANT-LINE area is in half raising position, low butt needle MISS and high butt needle KNIT.

Cam of CROSS-LINE area is in raising position and all butt needles is in no action. Following figures are with drawing description according to action.

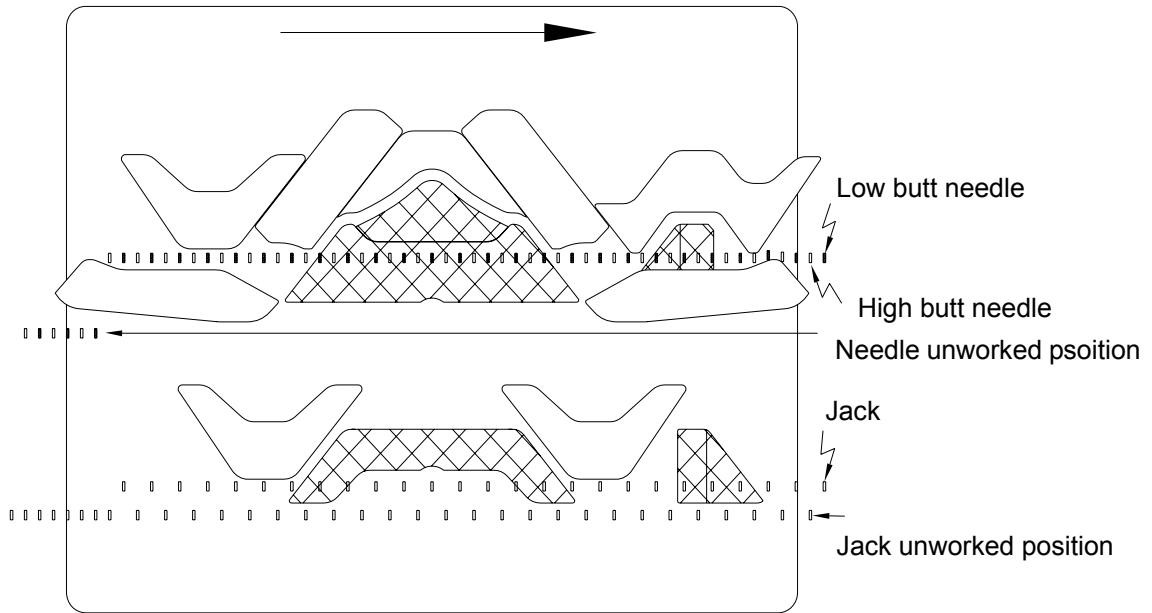

Fig.12-1 Command 0 : All butt needle MISS

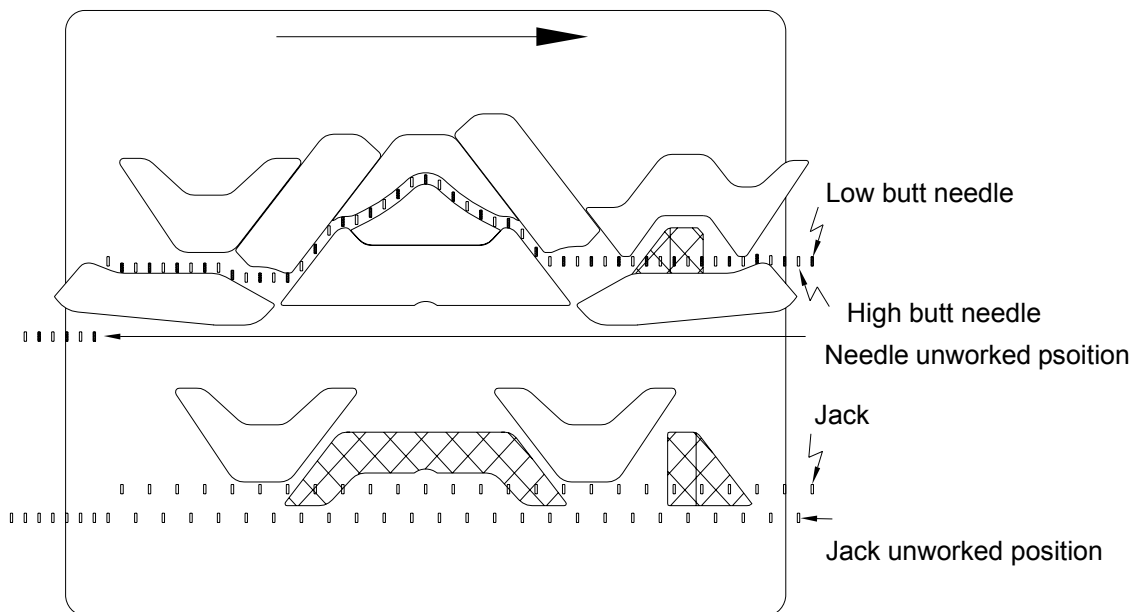

Fig.12-2 Command 1 : All butt needle KNIT



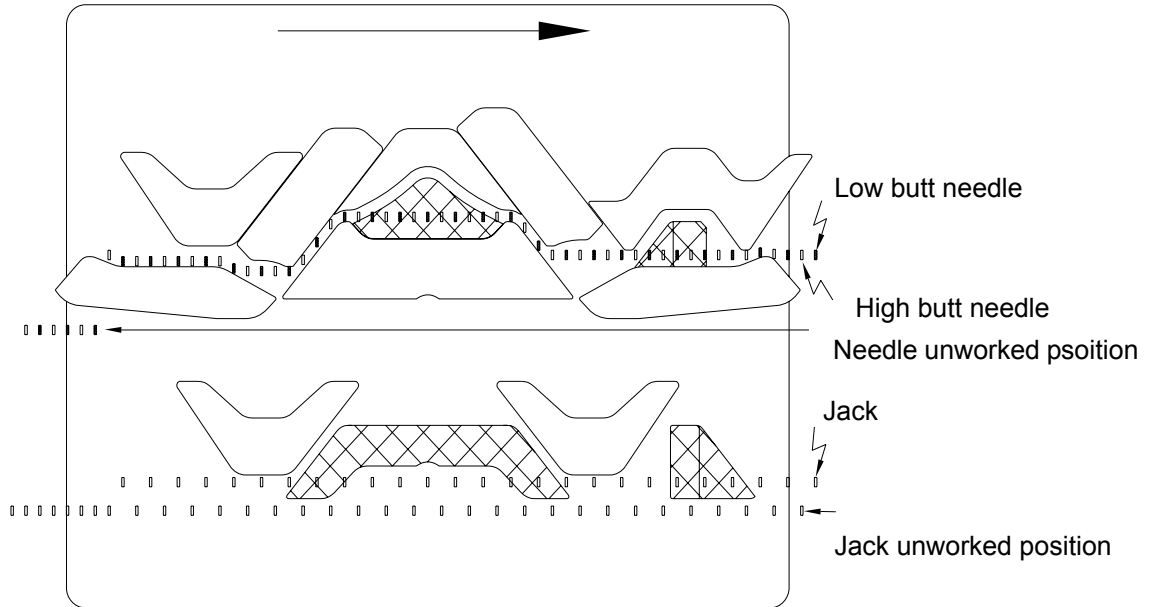

Fig.12-3 Command 2 : All butt needle TUCK

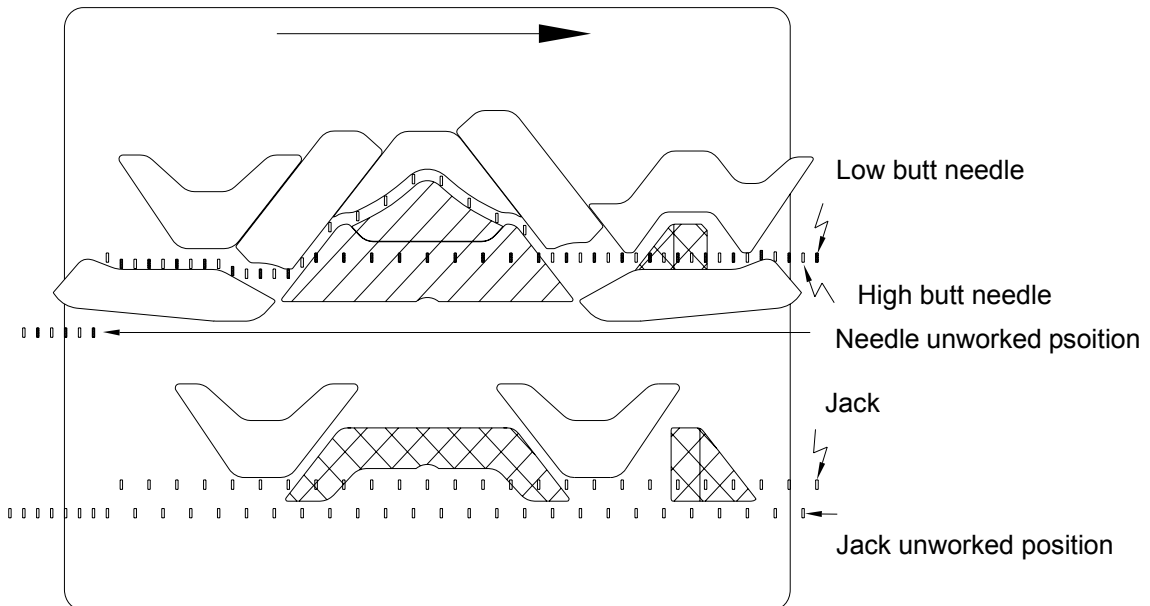

Fig.12-4 Command 3 : High butt needle KNIT

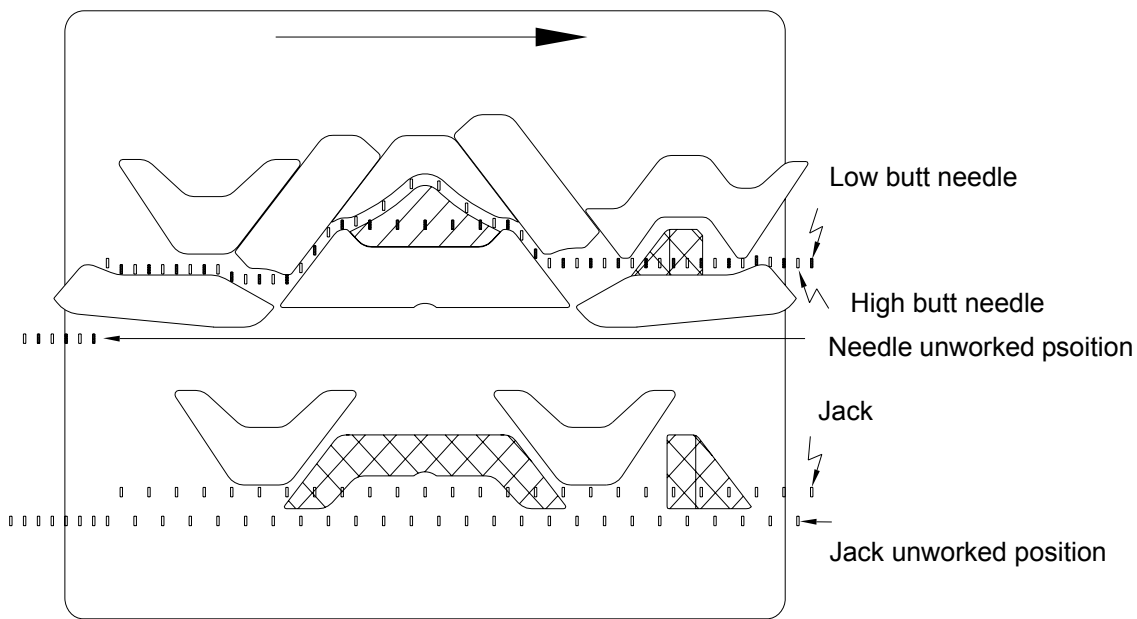

Fig.12-5 Command 4 : High butt needle KNIT

Low butt needle TUCK

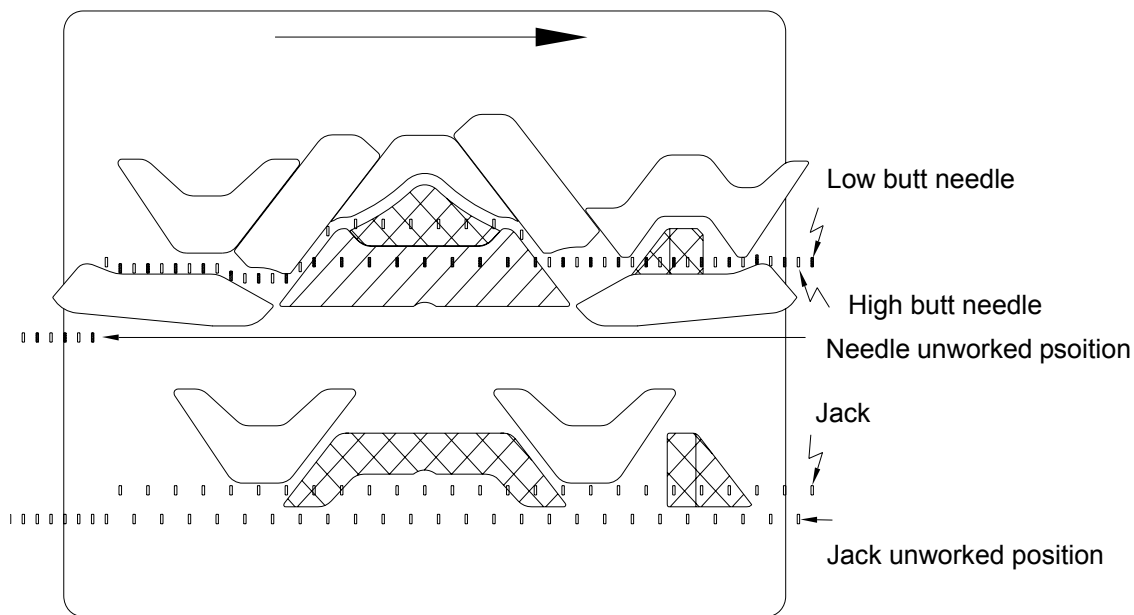

Fig.12-6 Command 5 : High butt needle TUCK

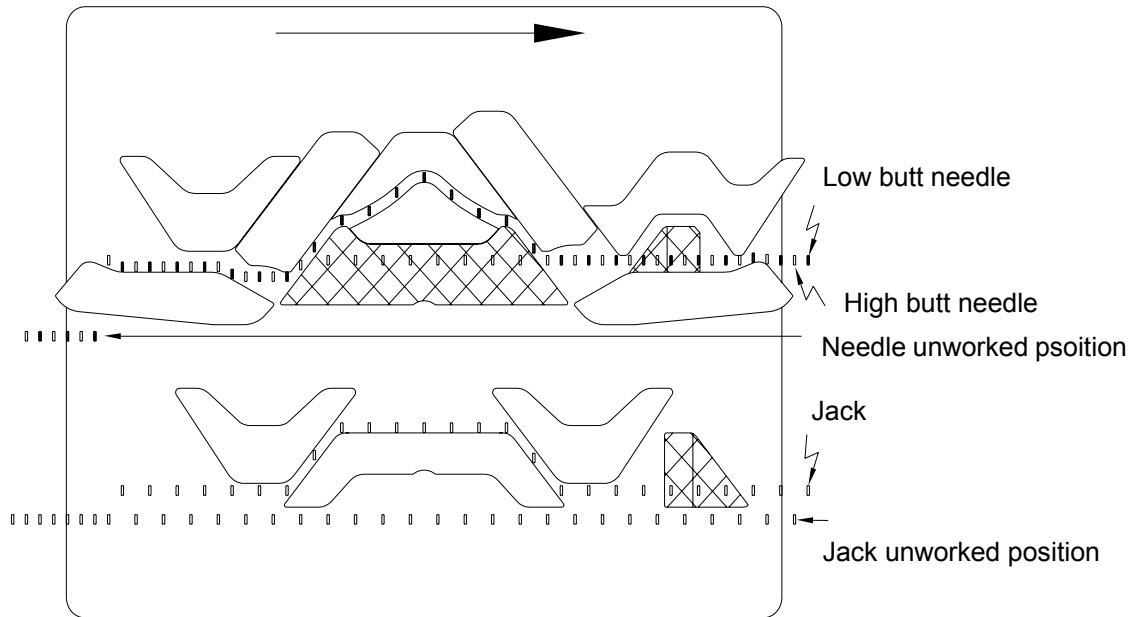

Fig.12-7 Command 6 : Jack KNIT

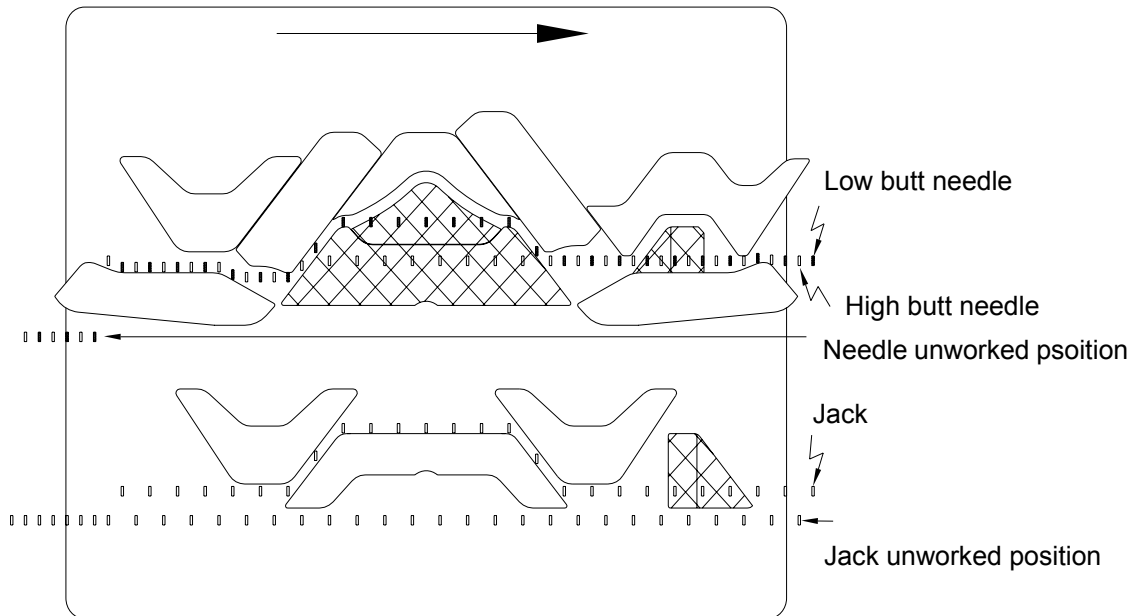

Fig.12-8 Command 7 : Jack TUCK

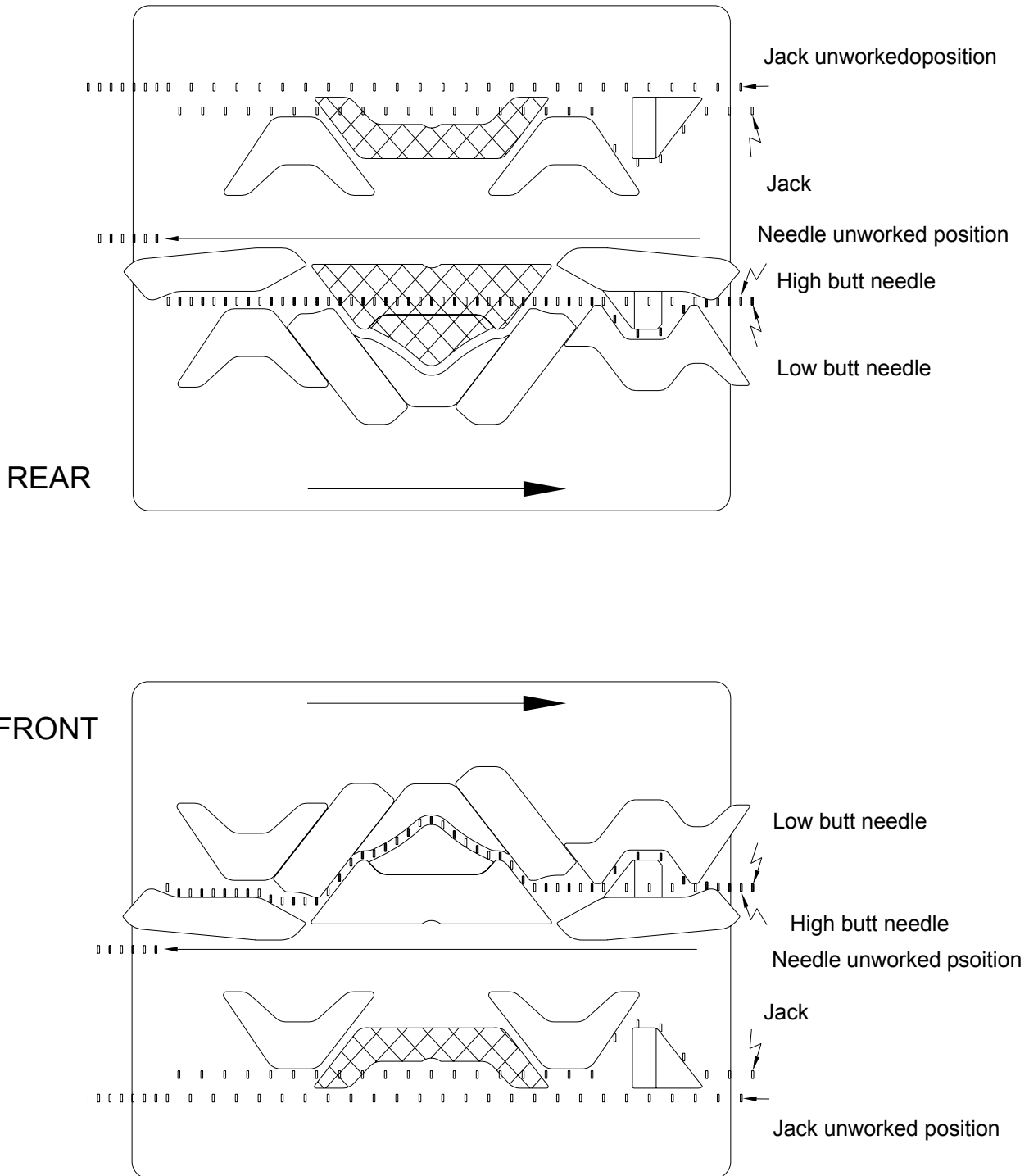

Fig.12-9 Command : 1 + Take-down : 5 KNIT + Lycra Jack TUCK

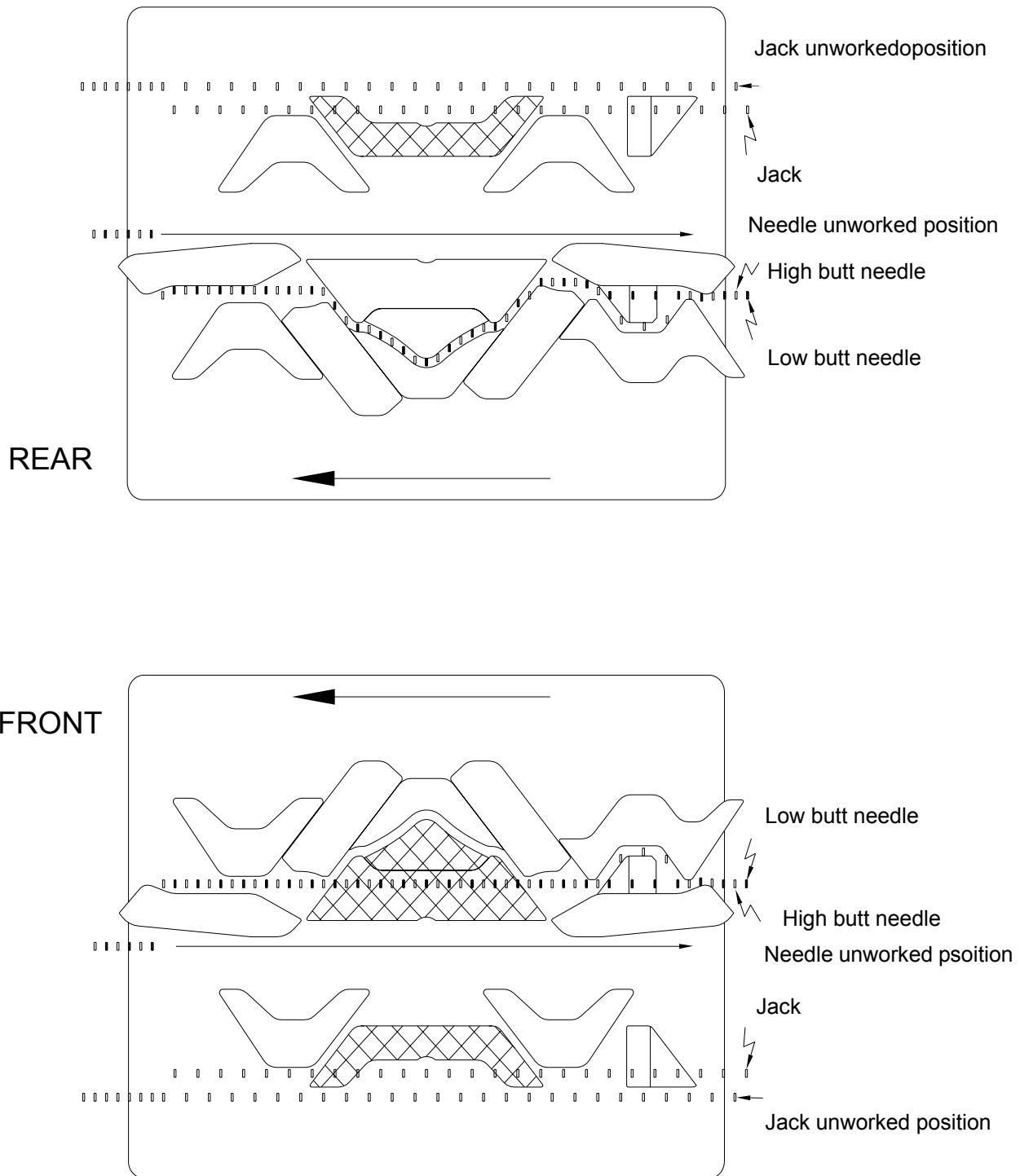

Fig.12-10 Command : 1 + Take-down : 5 KNIT + Lycra High butt needle TUCK

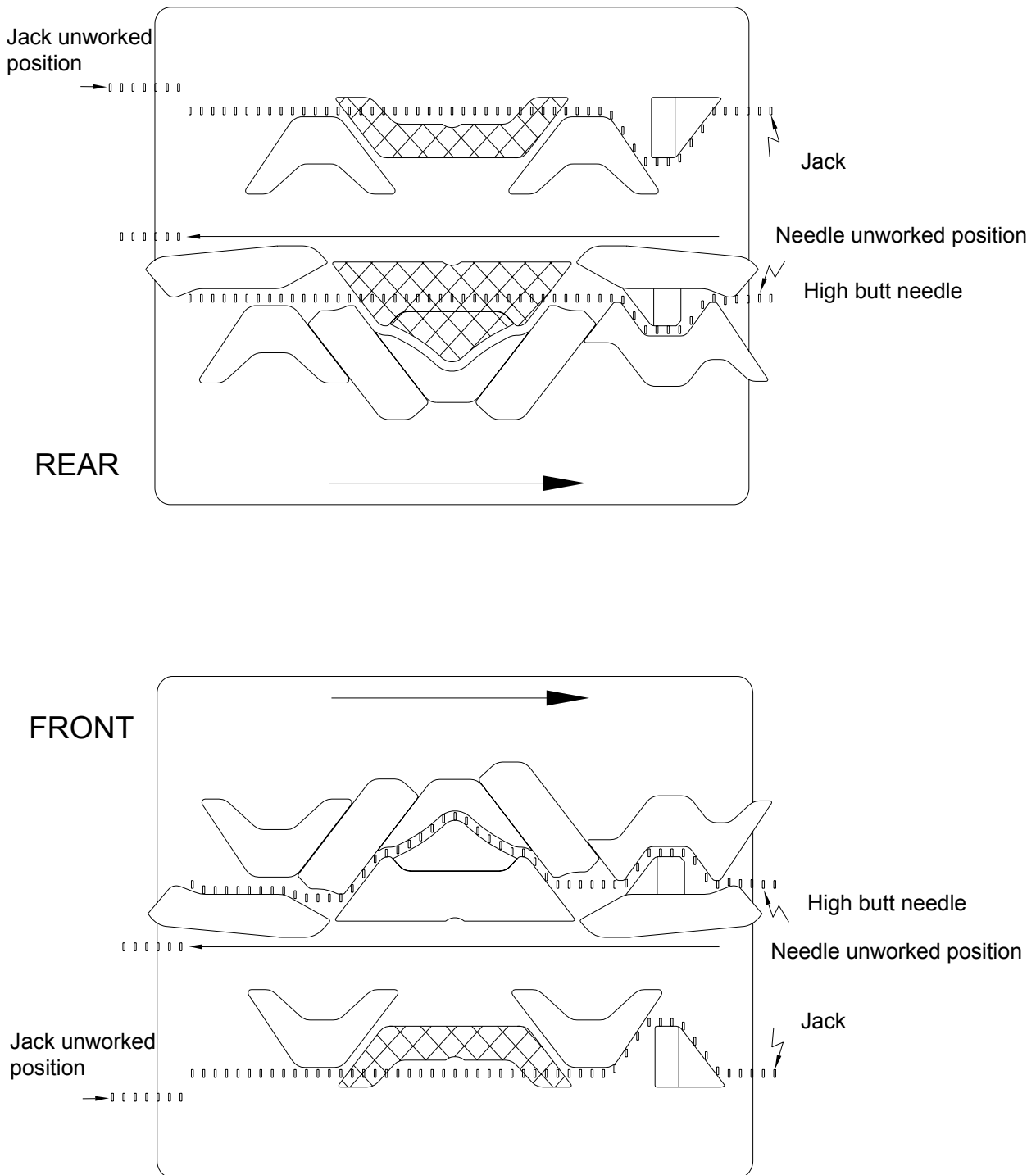

Fig.12-11 Command : 1 + Take-down : 5 KNIT + Lycra All butt needle TUCK

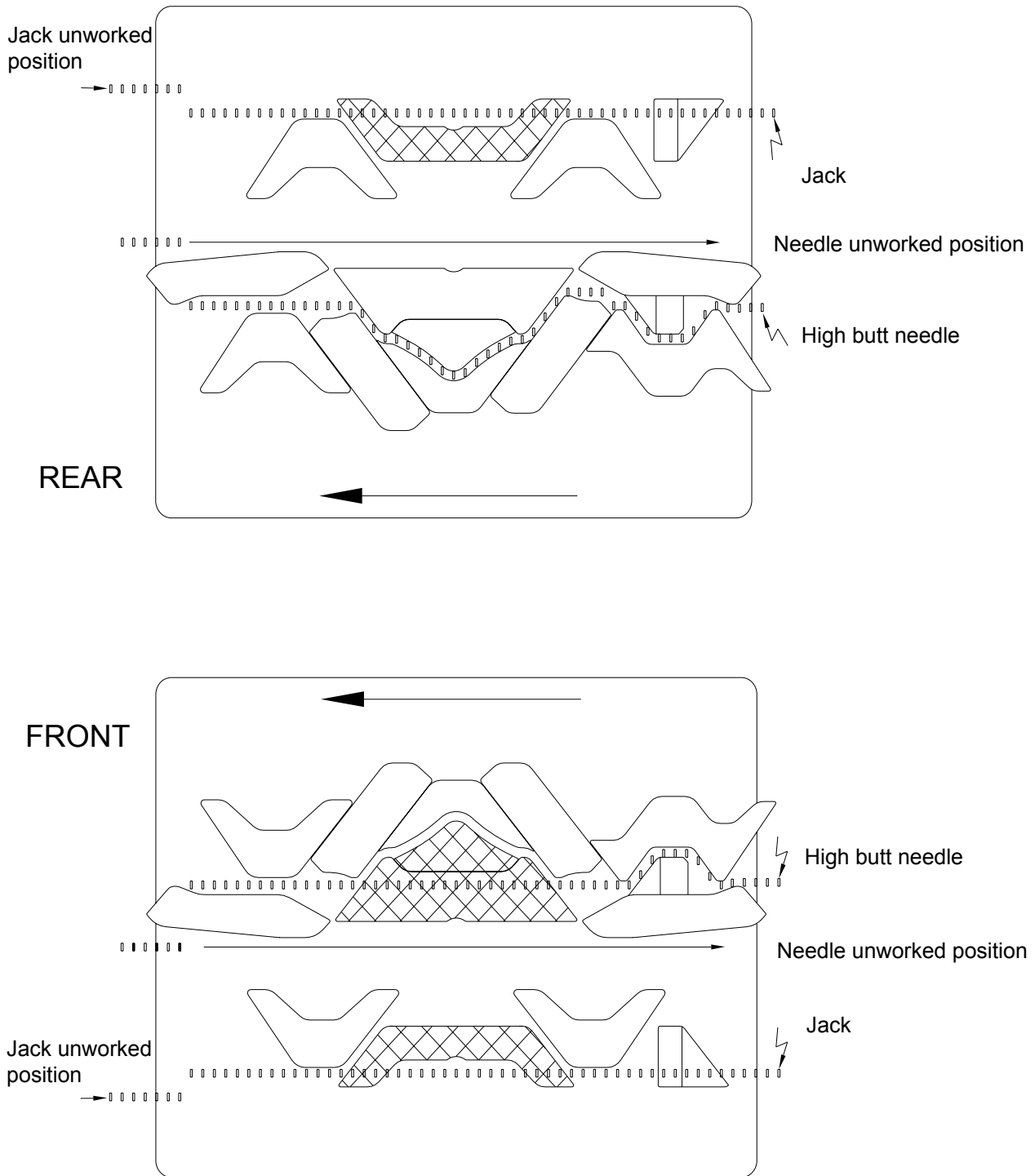
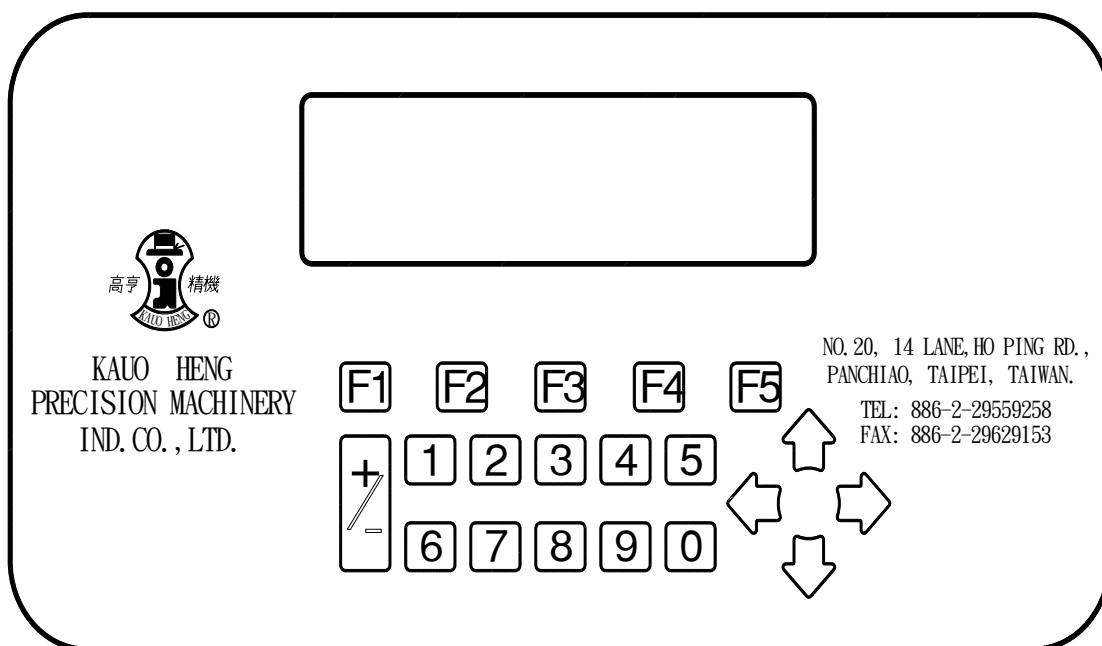

Fig.12-12 Command : 1 + Take-down : 5 KNIT + Lycra All butt needle TUCK

# INSTRUCTION MANUAL





**◎START**

Fig.0-1

When turning on the machine, it will appear this screen and display main menu after you press any key.

When you switch on the machine, then it displays **【MEMORY ERROR】** or **【FILE ERROR】** , you must switch off the machine and contact our agent or our service department.

There are five selections in main menu as Fig.0-2 illustrates and numeric corresponds to selection. Please directly press numeric key on keyboard then enter it.

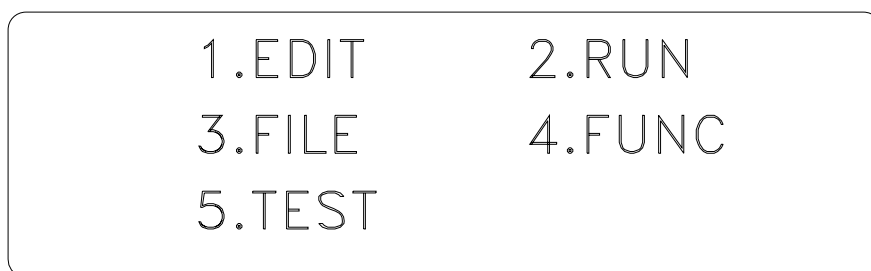

Fig.0-2

## 1. EDIT

Press **F1** in main menu, then display edit menu. There are five selections in edit menu as Fig.1-1 illustrates.

1. Open file    2. New file    3. Shift    4. Yarn carrier    5. Stitc

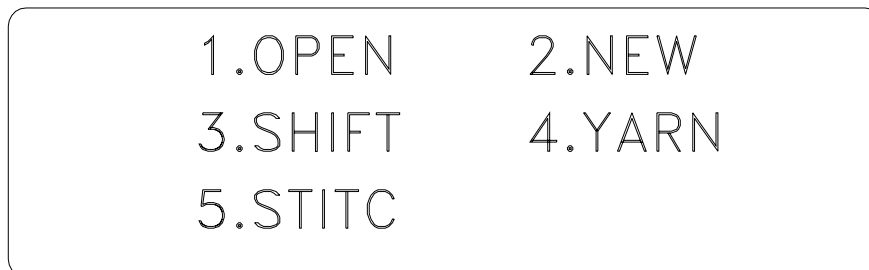

Fig.1-1

### 1-1 OPEN : Open file

Press **F1** in edit menu, and then the screen displays as Fig.1-2.



Fig.1-2

Remark : In screen there are five small squares, each one corresponds to

**F1** ~ **F5** on keyboard, blank means out of function. For example, in Fig.1-2, **F1** is SURE, **F2** ~ **F4** are blank in no function, **F5** is EXIT. In other screen menu the operation will be the same.

In Fig.1-2, input the file name with numeric, and press **F1** : SURE ; then enter program to edit.

When opening the file, input file name which is not existent. And the screen will appear Fig.1-3 warning screen, and then press **F1** to enter file or press **F5** to exit.



Fig.1-3

Edit screen appears two lines of instructions, cursor stops on the racking position, directly use numeric key and left, RIGHT key to edit instruction, or press UP, DOWN key change to other line. **+/-** key is for change of rack to left or right.

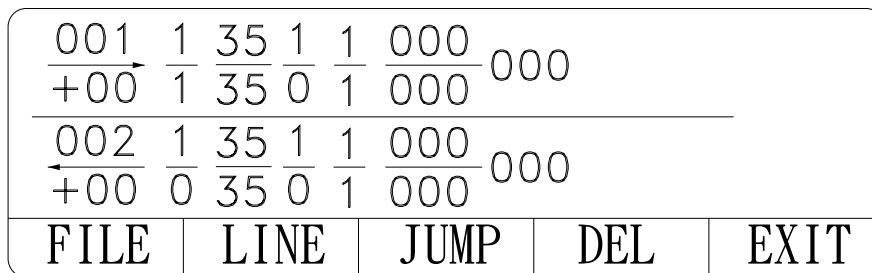
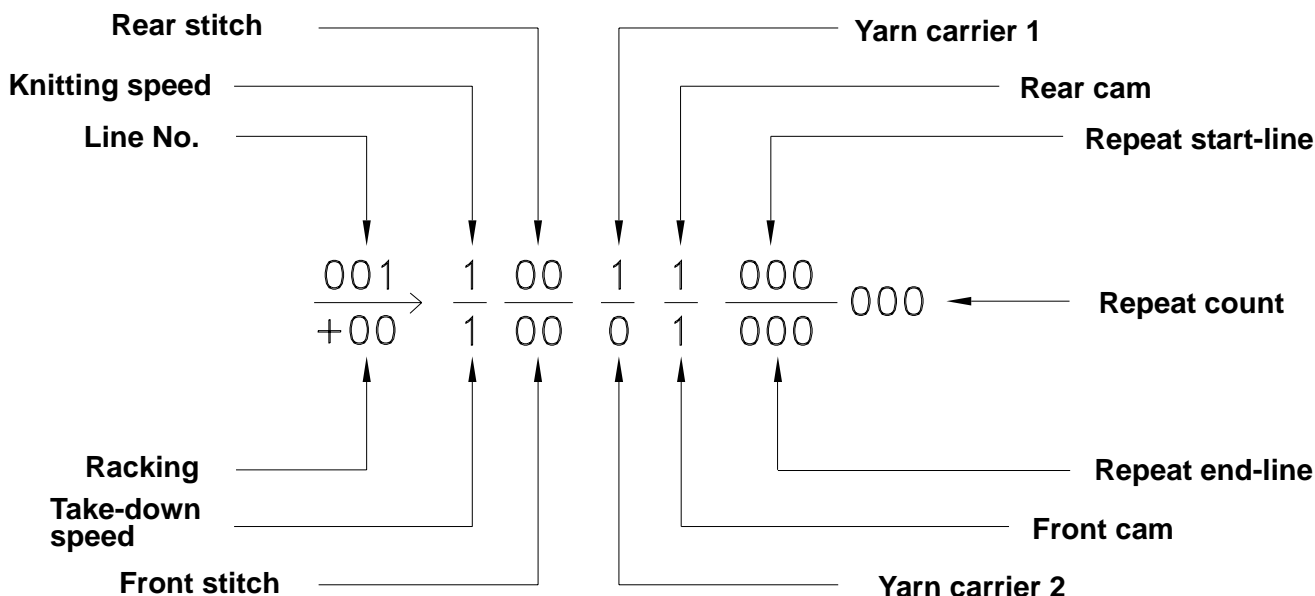

Fig.1-4 EDIT SCREEN

※ Edit instruction, and please refer the instruction explanation.

# INSTRUCTION EXPLANATION



Yarn carrier	0. None yarn carrier 1. 1~6	
Cam	0. Miss 1. All Knit 2. All Tuck 3. High Butt Needle Knit	4.High Butt Needle Knit Low Butt Needle Tuck 5.High Butt Needle Tuck 6.Jack Knit 7.Jack Tuck
Knitting speed	0. Same as previous line 1. 1 (Slow) ~7 (Fast)	Line No.1 is not allowed "0"
Take-down speed	0. Same as previous line 1. No.1 speed 2. No.2 speed	Take-down : 5 → Lycra Tuck Line No.1 is not allowed "0"
Racking	+ 10 Rack right 1 pitch - 10 Rack left 1 pitch	Face to the front of machine, you see the direction of movement of the rear bed.
Stitch	Setting from 0~99 (14G)	00 is zero (Tightest) Larger numeric gets longer loop.

EDIT SCREEN :

001	1	35	1	1	000	000
+00	1	35	0	1	000	000
002	1	35	1	1	000	000
+00	0	35	0	1	000	000
FILE	LINE	JUMP	DEL	EXIT		

**F1** FILE : Insert a file.

NAME: _____ NO: _____ (FILE)				
<table border="1" style="width: 100%; border-collapse: collapse;"> <tr> <td style="width: 25%;">SURE</td> <td style="width: 25%;"></td> <td style="width: 25%;"></td> <td style="width: 25%;">EXIT</td> </tr> </table>	SURE			EXIT
SURE			EXIT	

Fig.1-5 INSERT FILE

**F2** LINE : After current editing line inset a “ blank line ”, and the following lines are backward.

**F3** JUMP : This function is allowed jump to any line. If the input line No. is over total line, it will jump to the last line.

TO: _____ (JUMP)				
<table border="1" style="width: 100%; border-collapse: collapse;"> <tr> <td style="width: 25%;">SURE</td> <td style="width: 25%;"></td> <td style="width: 25%;"></td> <td style="width: 25%;">EXIT</td> </tr> </table>	SURE			EXIT
SURE			EXIT	

Fig.1-6 JUMP

**F4** DEL : Delete indicated lines.

FROM: _____ TO: _____ (DEL)				
<table border="1" style="width: 100%; border-collapse: collapse;"> <tr> <td style="width: 25%;">SURE</td> <td style="width: 25%;"></td> <td style="width: 25%;"></td> <td style="width: 25%;">EXIT</td> </tr> </table>	SURE			EXIT
SURE			EXIT	

Fig.1-7 DEL

**F5** EXIT : Press EXIT then the system will ask you to save this file, if it is not a new file, directly press **F1** SURE to use the same file name to save. The screen displays as Fig.1-9 then press **F1** If you don't want to save, press **F5** twice to exit.

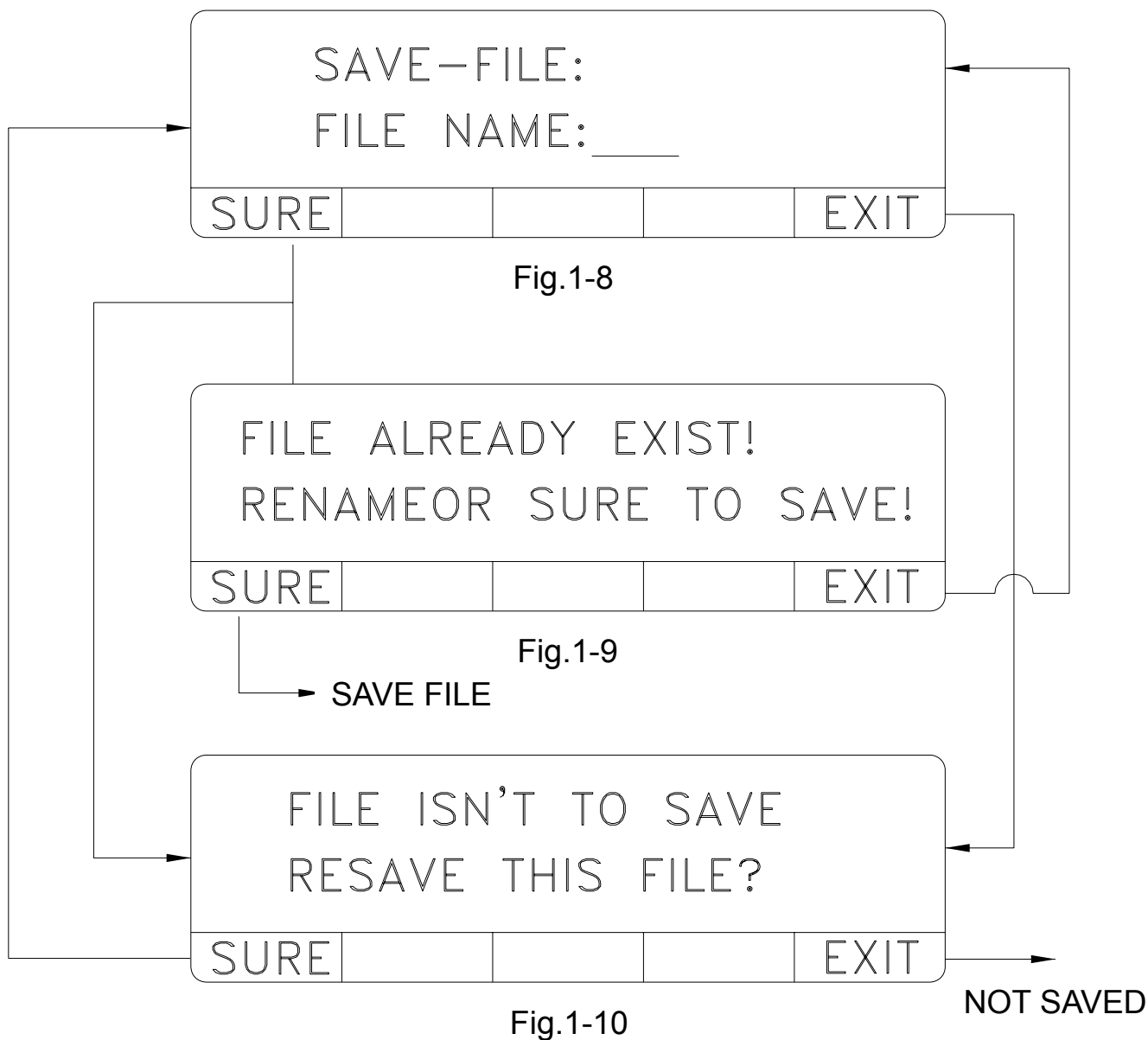

**1-2 NEW : New file**

After you edit the first line, press **F2** to insert blank line and go on editing.

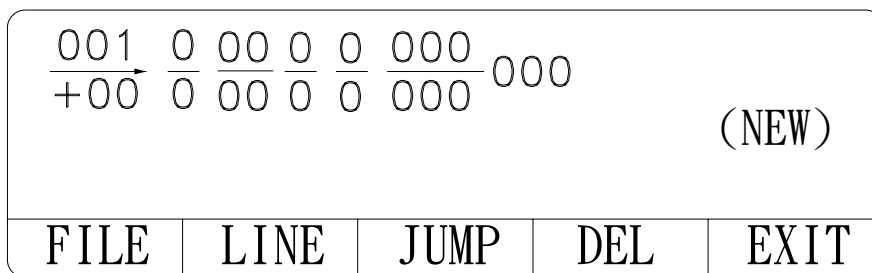

Fig.1-11

**1-3 SHIFT** : This function will copy left system to right system, or right system to left system, it contents of copy including cam, stitch, yarn carrier.



Fig.1-12 SHIFT

**1-4 YARN** : Quickly edit the working yarn carriers of any file.



Fig.1-13 YARN

**1-5 STITC** : Quickly edit the working stitch value of any file.

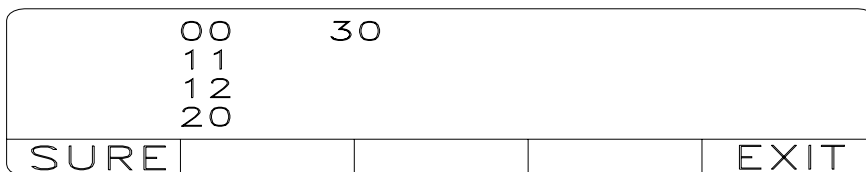

Fig.1-14 STITC

If it has conversion error and the screen displays as Fig.1-15, press **F5** to exit.



Fig.1-15 CONVERSION ERROR

## 2. RUN

1.EDIT	2.RUN
3.FILE	4.FUNC
5.TEST	

Fig.2-1

Press **2**

- ⊙ Enter RUN mode, if the stepping motor is not at home position, it displays warning **【STEP ERROR】**. You should go to the TEST mode, in STITCH function, you can test the stepping motor then come back to RUN mode.
- ⊙ Enter Run mode, if the carriage does not stop at the left limit position, it displays warning **【PLS MOVE CAM TO LEFT】**. You have to move the carriage to the left limit position and start.

NAME: 001	T-RW: 0204
YN-L: 103000	F-LN: 024
T-PC: 9999	F-PC: 0025
SURE	EXIT

Fig.2-2

Enter Fig.2-2, set the knitting file name, and then set T-PC (total pieces), F-PC (finished pieces), after setting press **F1** to enter Fig.2-3.

001	1	35	1	1	000	000
+00	1	35	0	1	000	
002	1	35	1	1	000	000
+00	0	35	0	1	000	
SURE	EDIT	1 PC	HOME	EXIT		

Fig.2-3

**F1** RUN. **F2** EDIT : Edit stitch value and knitting speed. See Fig.2-8 and Fig.2-9 and Fig.2-10.

**F3** 1 PC : Knit 1 piece and stop machine.

**F4** HOME : Give up the fabric on knitting. The method you turn the operation bar to stop machine, and press **F4** to make cam and stitch to home position, and then start the operation bar to make the carriage return to left beginning position.

**F5** EXIT :



## ERROR MESSAGE

After you finish inputting the instruction for the program that occurs incorrect action or wrong instruction to the function of machine, it will automatically appear ERROR message on RUN mode.

Please correct the error of edited program according to the error message of LCD display.

Error message table

Message	Explanation
Line not even	To edit a program, the total lines of program must be an even number. Otherwise the carriage does not return to the left side to proceed the next knitting piece.
Carrying feeder	It is an error that the carriage carries a yarn feeder when you set carriage in an empty action without yarn feeder.
None feeder ( L )	When you set the action of knit, the carriage has to carry a yarn feeder.
None feeder ( R )	
Rack error	Before ending the program, the needle bed must be racked back to the home position. In case the program racks one level to the right, it needs rack one level to the left back to the home position before ending.
Feeder 1 error	Before ending the program, the yarn feeder must return to home position, Otherwise it is impossible to proceed the next knitting piece.
Feeder 2 error	
Feeder 3 error	
Feeder 4 error	
Feeder 5 error	
Feeder 6 error	
Repeat error	Repeat must be set in even lines of amount, for example the start line is an odd and the end line must be an even, or from an even to an odd. ( From odd line to odd line or from even line to even line are unacceptable. )
Rack over speed	In racking, the maximum of knitting speed is No.4.
Start-ndl error	The number of start-needle must be smaller than the number of end-needle.
End-ndl error	The number of end-needle must be larger than the number of start-needle, or smaller than the number of total-needle.

Tab.2-1 Error message table

**F2** EDIT :

1.STITCH      2.SPEED				
SURE				EXIT

Fig.2-8 Edit stitch value & knitting speed

Press **1** enter Fig.2-9

Press **2** enter Fig.2-10

00      30				
11				
12				
20				
SURE				EXIT

Fig.2-9

Fig.2-9 displays all the used stitch value of file. Directly move the cursor to the area of being changed, and press the numeric key to correct it. For example, in Fig.2-9 the 12 is replaced by 15, then all the stitch value 12 is/are changed with 15 in this file.

SPEED-EXCHANGE				
LINE SPEED				
001	0	—	—	—
SURE				EXIT

Fig.2-10

Fig.2-10 displays the exchange of knitting speed. Directly press the numeric key to change it, or press UP/DOWN key to the changed line and correct it.

※Machine stop : If the fault signal ( auto-stop equipment ) is operated, it will display the fault signal as Fig.2-11, and corrective action refer to Table 2-2.

001	1	35	1	1	000	000	(T-TSN)
+00	1	35	0	1	000		
002	1	35	1	1	000	000	
+00	0	35	0	1	000		
SURE	EDIT	1 PC	HOME	EXIT			

Fig.2-11

SIGNAL	FAULT	CORRECTIVE ACTION	REMARK
T-TSN	Yarn break Tension loose Yarn knot	After corrective action, turn the operation bar to clear, and restart the operation bar and go on knitting.	
S-TSN	Yarn break Tension loose		
DETR	Needle break Fabric rise		
TK-DN	Fabric fall Fabric roll-up		
STOP	Safty cover is not closed.		
OVER	Motor rotates without signal of detector. Overload of inverter.	Switch off power and switch on after 5 sec. Switch off power to check power in correct then switch on.	Pls contact our agent or service dept., if you still can't correct the fault.
LEFT/ RIGHT	Carriage is stroke error.	Push the carriage out of limit sensor.	
STEP	Stepping motor error	Press <b>F4</b> HOME to return carriage to left limit position. Exit RUN mode and go to TEST mode to test stitch value and go back RUN.	
RACK	Racking error	Press <b>F4</b> HOME to return carriage to left limit position. Exit RUN mode and go to TEST mode to test racking and go back RUN.	

Table 2-2 Machine stop

### 3. FILE

1.DISP	3.DEL
3.COPY	4.TRANS
5.REVD	6.CLEAR

Fig.3-1

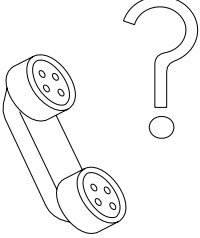
#### 3-1 DISP : Display

Fig.3-2 move cursor to select the displayed file name, and press **F1** SURE, Fig. 3-3 will execute program once simultaneously, and display screen Fig.3-4. Please press **F1** or **F5** to come back to Fig.3-2 after confirmation.

<u>001</u>	002	020	005
04	FILE	00483	BYTES
		24349	BYTES FREE
SURE			EXIT

Fig.3-2

<u>001</u>	1	35	1	1	000	000
+00	1	35	0	1	000	
<hr/>						
<u>002</u>	1	35	1	1	000	000
+00	0	35	0	1	000	
FILE	LINE	JUMP	DEL	EXIT		

Fig.3-3

NAME:001	MEM:001
YN-L:103000	YN-R:020400
T-RW:006	F-LN:006
SURE	EXIT

Fig.3-4

NAME : File name and it's size of used memory

Yarn carrier of left & right carriage

T-RW : Total executive lines, F-LN : Total file lines

**3-2 DEL** : Delete the input file name, and press **F1** for sure. :

DEL-NAME:				
SURE				EXIT

Fig.3-5

**3-3 COPY** : Input source and target file names and press **F1** for sure.

COPY:            TO:				
SURE				EXIT

Fig.3-6

**3-4 TRANS** : Transmits file to another machine, firstly confirm if the plug has been connected with connection cable on back of controller.

TRANS:				
SURE				EXIT

Fig.3-7

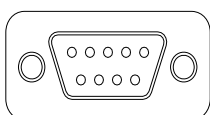

Fig.3-8

Plug for transmitted file on the back of controller

**3-5 REVD** : Receive the transmitting file from another machine, firstly confirm if the plug has been connected with connection cable on the back of controller, and press **F1** for sure then start to receive.

REVD:				
SURE				EXIT

Fig.3-9

**3-6 CLEAR : Clear all files**

DO YOU CLR:				
SURE				EXIT

DELETE ALL FILE !				
SURE				EXIT

Enter code No : 555

DELETE ALL FILE : <u>555</u>				
SURE				EXIT

Fig.3-10

### 4. FUNCTION

1.STITC	2.TYPE
3.BUZZ	4.MODE

Fig.4-1

**4.1 STITC** : Stitch parameters, directly adjust with numeric.

REAR					
LEFT	$\frac{30}{30} + \frac{30}{30}$	RIGHT	LEFT	$\frac{30}{30} + \frac{30}{30}$	RIGHT
FRON					
SURE				EXIT	

Fig.4-2

**4.2 TYPE** : Setting gauge and total needles, initial setting by manufacturer.

GAUGE:14				
T-NDL:1120				
SURE				EXIT

Fig.4-3

**4.3 BUZZ** : Setting buzzer function in action or not.

KEYBOARD:CLOSE				
ERROR:OPEN				
SURE	OPEN		CLOS	EXIT

Fig.4-4

**4.4 MODE** : Setting display mode **F2** in English and **F4** in Chinese.

F2.ENGLISH				
F4.中文				
SURE				EXIT

Fig.4-5

### 5. TEST

1.RACK	2.MOTOR
3.SENSO	4.CAM
5.TK-DN	6.STITC

Fig.5-1

#### 5.1 RACK :

◀ RACK LEFT ▶ RACK RIGHT NOTE! RACK-POSITION				
SURE				EXIT

Fig.5-2

#### 5.2 MOTOR :

OPERATION BAR ↑ INCHING OPERTAION BAR ↓ RUN MAIN-MOTOR TEST				
SURE				EXIT

Fig.5-3

#### 5.3 SENSO : Sensor

Test when they are switched on. Sensor with a small square appears in the front.

T-TSN	S-TSN	RIGHT	
◻LEFT	TK-DN	OVER	
RACK	DETR	START	
INCH	MEM	COVER	
SURE			EXIT

Fig.5-4

T-TSN	Top tension	RACK	Racking
S-TSN	Side tension	DETR	Detector
RIGHT	Right limit sensor	START	Operation bar starting
LEFT	Left limit sensor	INCH	Operation bar inching
TK-DN	Fabric take-down	MEM	Memory error
OVER	Main motor overload	COVER	Safety cover



**5.4 CAM** : Move cursor to make the cam or the yarn feeder solenoid in action.

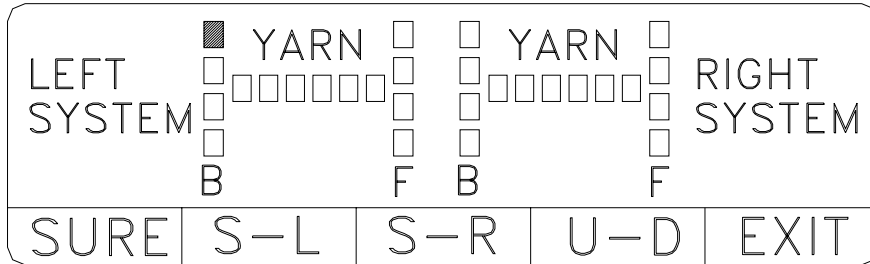

Fig.5-5

**5.5 TK-DN** : Setting the speed of fabric take-down, press ►◀ key then turn the operation bar.

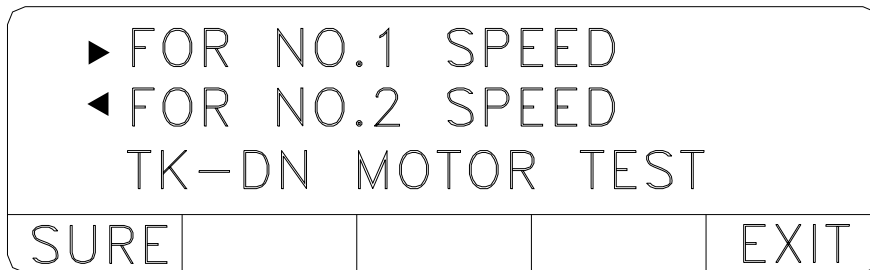

Fig.5-6

**5.6 STITC : Stitch**

Press **F1** ~ **F4** to test.

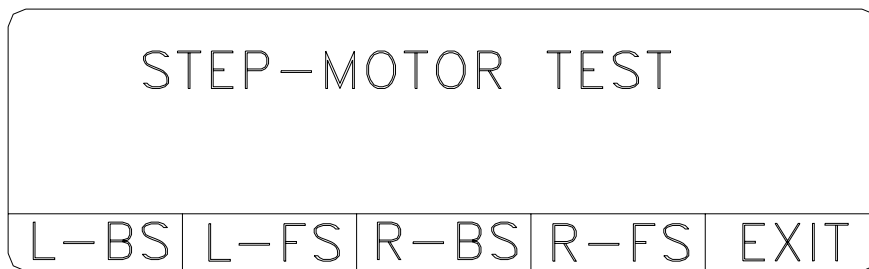

Fig.5-7

**5.7 KEYBOARD** : Test if it works or not then press **F5** to exit.

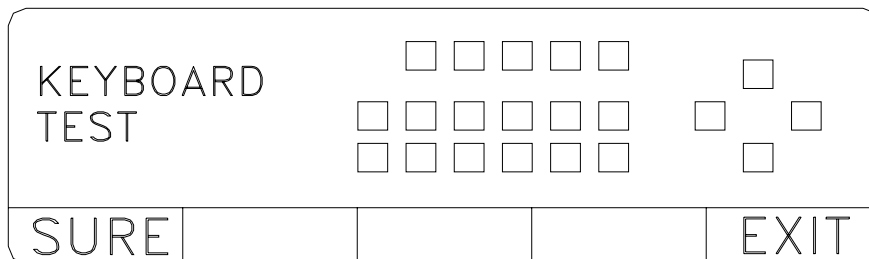

Fig.5-8



# 高亨精機工業有限公司

KH-313N

**FILE  
NAME**

**PAGE**

Line No.	Knitting Speed	Rear Stitch	Yarn Carrier	Rear Cam	Repeat Start-Line	Repeat Count	Description
Rack	Take down Speed	Front Stitch		Front Cam	Repeat End-Line		
<input type="checkbox"/> <input type="checkbox"/> <input type="checkbox"/> 1	<input type="checkbox"/>	<input type="checkbox"/> <input type="checkbox"/>	<input type="checkbox"/>	<input type="checkbox"/>	<input type="checkbox"/> <input type="checkbox"/> <input type="checkbox"/>	<input type="checkbox"/> <input type="checkbox"/> <input type="checkbox"/>	<p>Line No.001 is not allowed "0" for knitting speed and take-down speed</p> <hr/> <p><b>Rack:</b> +10 Right 1 pitch -10 Left 1 pitch</p> <hr/> <p><b>Knitting Speed:</b> 0.Same as previous line 1(Slow)~7(Fast)</p> <hr/> <p><b>Take-down Speed:</b> 0.Same as previous line 1. No.1 speed 2. No.2 speed 3. No.5 Tuck cam for Lycra</p> <hr/> <p><b>Yarn carrier:</b> 0. None yarn carrier 1. No.1 yarn carrier 2. No.2 yarn carrier 3. No.3 yarn carrier 4. No.4 yarn carrier 5. No.5 yarn carrier 6. No.6 yarn carrier</p> <hr/> <p><b>Cam:</b> 0.Miss 1.Knit 2.Tuck 3.High butt knit 4.High butt knit, low butt tuck 5.High butt tuck 6.Jack knit 7.Jack tuck</p> <hr/> <p><b>Stitch: 00~99</b></p>
<input type="checkbox"/> <input type="checkbox"/> <input type="checkbox"/> 2	<input type="checkbox"/>	<input type="checkbox"/> <input type="checkbox"/>	<input type="checkbox"/>	<input type="checkbox"/>	<input type="checkbox"/> <input type="checkbox"/> <input type="checkbox"/>	<input type="checkbox"/> <input type="checkbox"/> <input type="checkbox"/>	
<input type="checkbox"/> <input type="checkbox"/> <input type="checkbox"/> 3	<input type="checkbox"/>	<input type="checkbox"/> <input type="checkbox"/>	<input type="checkbox"/>	<input type="checkbox"/>	<input type="checkbox"/> <input type="checkbox"/> <input type="checkbox"/>	<input type="checkbox"/> <input type="checkbox"/> <input type="checkbox"/>	
<input type="checkbox"/> <input type="checkbox"/> <input type="checkbox"/> 4	<input type="checkbox"/>	<input type="checkbox"/> <input type="checkbox"/>	<input type="checkbox"/>	<input type="checkbox"/>	<input type="checkbox"/> <input type="checkbox"/> <input type="checkbox"/>	<input type="checkbox"/> <input type="checkbox"/> <input type="checkbox"/>	
<input type="checkbox"/> <input type="checkbox"/> <input type="checkbox"/> 5	<input type="checkbox"/>	<input type="checkbox"/> <input type="checkbox"/>	<input type="checkbox"/>	<input type="checkbox"/>	<input type="checkbox"/> <input type="checkbox"/> <input type="checkbox"/>	<input type="checkbox"/> <input type="checkbox"/> <input type="checkbox"/>	
<input type="checkbox"/> <input type="checkbox"/> <input type="checkbox"/> 6	<input type="checkbox"/>	<input type="checkbox"/> <input type="checkbox"/>	<input type="checkbox"/>	<input type="checkbox"/>	<input type="checkbox"/> <input type="checkbox"/> <input type="checkbox"/>	<input type="checkbox"/> <input type="checkbox"/> <input type="checkbox"/>	
<input type="checkbox"/> <input type="checkbox"/> <input type="checkbox"/> 7	<input type="checkbox"/>	<input type="checkbox"/> <input type="checkbox"/>	<input type="checkbox"/>	<input type="checkbox"/>	<input type="checkbox"/> <input type="checkbox"/> <input type="checkbox"/>	<input type="checkbox"/> <input type="checkbox"/> <input type="checkbox"/>	
<input type="checkbox"/> <input type="checkbox"/> <input type="checkbox"/> 8	<input type="checkbox"/>	<input type="checkbox"/> <input type="checkbox"/>	<input type="checkbox"/>	<input type="checkbox"/>	<input type="checkbox"/> <input type="checkbox"/> <input type="checkbox"/>	<input type="checkbox"/> <input type="checkbox"/> <input type="checkbox"/>	
<input type="checkbox"/> <input type="checkbox"/> <input type="checkbox"/> 9	<input type="checkbox"/>	<input type="checkbox"/> <input type="checkbox"/>	<input type="checkbox"/>	<input type="checkbox"/>	<input type="checkbox"/> <input type="checkbox"/> <input type="checkbox"/>	<input type="checkbox"/> <input type="checkbox"/> <input type="checkbox"/>	
<input type="checkbox"/> <input type="checkbox"/> <input type="checkbox"/> 0	<input type="checkbox"/>	<input type="checkbox"/> <input type="checkbox"/>	<input type="checkbox"/>	<input type="checkbox"/>	<input type="checkbox"/> <input type="checkbox"/> <input type="checkbox"/>	<input type="checkbox"/> <input type="checkbox"/> <input type="checkbox"/>	

<b>FILE NAME</b>	<b>TOTAL EXECUTIVE LINE</b>	
<b>DATE</b>	<b>PRODUCTION</b>	<b>min./pc</b>
Carriage must be on left side for starting		